

# Extraction of VBIC Model Parameters for Large-Signal Model of SiGe HBTs

Kyungho Lee, Byounguk In\*, Daekyu Yu, Bumman Kim, Sangjung Jeon\*\*, and Youngkwang Kim\*\*

Dept. of E. E. Eng. and MARC, POSTECH, \*GCS, Inc. 23155 Kashiwa Court, Torrance, CA 90505-4026, USA,

\*\* New Device Development PJT, System LSI Division, Device Solution Network, Samsung Electronics co., Ltd.

## ABSTRACT

This paper presents a practical method for extracting the VBIC model parameters of SiGe Heterojunction Bipolar Transistors (HBTs). The several important parameter extraction methodologies are investigated and the process flow is shown. The simulation results of the extracted VBIC model are compared with the measurement data and show good agreements in both DC and S-parameters. To assess accuracy of the model for linear power amplifier design, the power and two-tone measurements are compared with the simulation results based on the model. Although the power measurement and simulation results are in a good agreement, the harmonic characteristics show a large discrepancy.

## 1. INTRODUCTION

SiGe HBT is the first practical bandgap-engineered silicon device. Due to its high-speed performance and mature silicon process, the SiGe HBT has emerged as technology of the choice for RFICs. Therefore, an accurate model of the device is indispensable for an RF circuit designer.

For nearly 30 years, the industry standard for bipolar junction transistor modeling has been Spice Gummel-Poon (SGP) model. However, SGP has several limitations such as parasitic transistor, Kirk effect, etc. Several advanced models, such as VBIC, HICUM, and MEXTRAM have been proposed and currently under evaluation [1][2].

In this paper, we have investigated the VBIC model for large-signal modelling of the SiGe HBT. An accurate and efficient methodology to extract VBIC model parameters is presented. The accuracy of the model has been evaluated. The simulated results using the extracted VBIC model are in good agreements in DC, S-parameters, and RF power measurement data. We also evaluate the harmonic characteristics of the VBIC model but we found that the model is not accuracy enough.

## 2. MODEL PARAMETER EXTRACTION AND MODELING

Figure 1 shows the equivalent circuit of VBIC[1], which includes an intrinsic transistor, a parasitic transistor, parasitic resistances and capacitances, a thermal circuit, and a excess phase circuit. Despite the complexity of the VBIC model, all elements should be considered as voltage controlled current sources or charges. Thus, the parameter extraction is divided into roughly three categories – current sources, charges, and parasitics.

We performed parameter extraction for a  $2 \times 0.6 \mu\text{m} \times 25 \mu\text{m}$  ( $5 \times 5 \mu\text{m}$ ) SiGe HBT fabricated by  $0.35 \mu\text{m}$  SiGe BiCMOS process technology at Samsung Electronics co., Ltd. For accurate measurements, microwave probes in G-S-G configurations are utilized. Figure 2 shows a flowchart for the VBIC model parameter extraction and optimization procedure used in this work[3]. Details are as follows.

Prior to performing DC parameter extraction, junction depletion capacitances and bias independent parasitic capacitances should be extracted from “cold” S-parameters at reverse and low forward biases. These results are depicted in figure 3. The next step is to calculate Early effect parameters from the extracted junction capacitance parameters. Diode parameters are extracted at a low bias current and are partially tuned with Early effect parameters.

The series resistances are determined from flyback measurements and “hard-saturation” S-parameter and are compared. The knee current parameters, which represent a high level injection, are obtained from DC current gain fall-off phenomena, partial optimization with the diode parameters extracted a low-bias and the

series resistances. Figure 4 shows the measured and simulated Gummel plots and corresponding DC current gains.

Transit time parameters / diffusion capacitance modeling, and excess phase delay modeled for non-quasi static effect, are extracted following reference [4] and are shown in figure 5. The temperature mapping such as thermal resistance related to the device self-heating and ambient temperature is extracted from DC Gummel plots at 20, 50, and 80°C. The results are depicted in figure 6.

After the several important model parameter extractions, we have constructed a macro-model which includes non-VBIC parameters such as parasitic lead inductances and performed global optimization for fitting all DC and AC parameters. Most of these optimizations are carried out in circuit simulator, Agilent’s ADS.

## 3. MODEL VERIFICATIONS AND DISCUSSIONS

Figures 7 and 8 compare the measurement and simulation results of the DC I-V characteristics under forward operation at forced  $I_B$  and  $V_{BE}$ , respectively. As shown in the figures, the simulation results are in good agreements with the measurements. Figure 9 shows S-parameters under various bias conditions from the measurement and the simulation of VBIC large-signal model. Again, they fit very well. For further model verification, RF power measurement and two-tone test results are compared with simulation results, which are shown in figure 10. The RF power simulation results follow the measurement data. However, two-tone simulation results show large discrepancies with measurements. We think that the large are arisen from inaccurate formulation (e.g. lack of current dependency) of base-collector charge model of VBIC, which is dominant nonlinear source of BJTs[5]. Further investigation is required in this area.

## 4. CONCLUSION

A large-signal modeling of SiGe HBT is performed through the extraction of VBIC model parameters. The simulation of extracted VBIC model shows good agreements in DC, S-parameter, and power measurement results. However, our results show that VBIC has inaccuracy for the nonlinear behavior of SiGe HBT due to the base-collector charge model.

## 5. REFERENCES

- [1] C. C. McAndrew, et. al., *IEEE JSSC*, vol.31, no.10, pp.1476, 1996.
- [2] [Online] [www.eigroup.org/cmc](http://www.eigroup.org/cmc)
- [3] G. W. Huang, et. al., *IEEE APMC*, pp.240, 2001.
- [4] S. Lee., *IEEE TED*, vol.43, no.11, pp.2027, 1996.
- [5] W. Kim, et. al., *IEEE MTT*, vol.49, no.7, pp.1270, 2001.

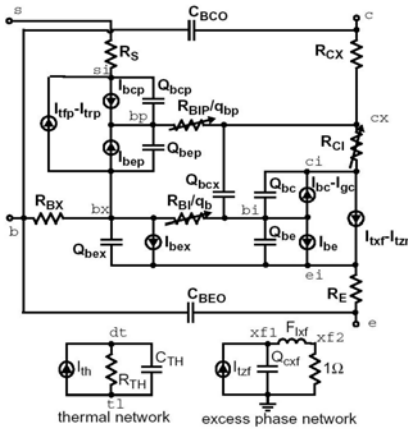

Fig. 1. Equivalent circuit of the VBIC model

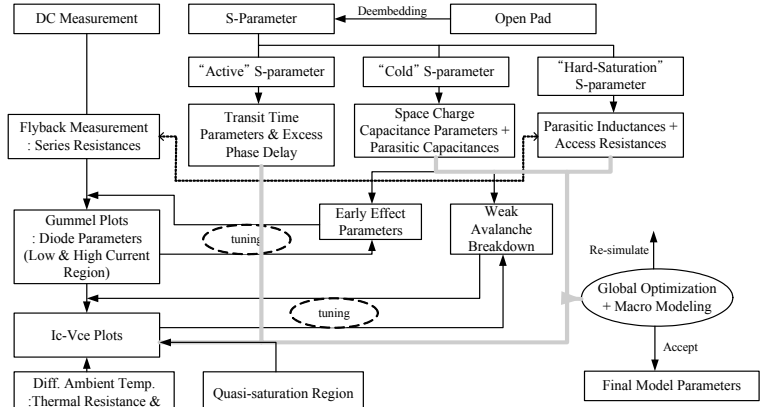

Fig. 2. Flowchart for the VBIC model parameter extraction and optimization

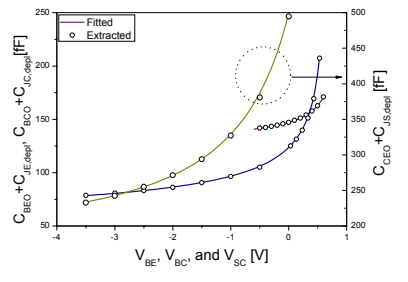

Fig. 3. Junction depletion capacitances.

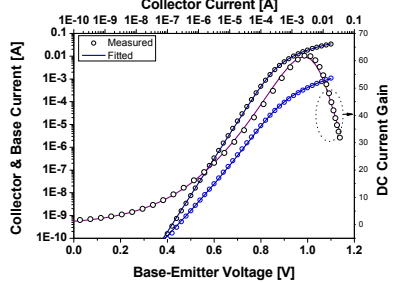

Fig. 4. Gummel plot and corresponding  $\beta$ .

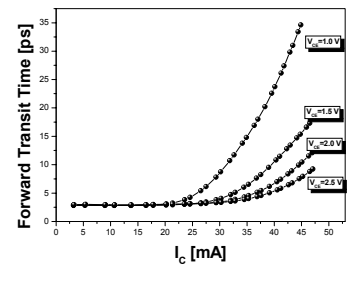

Fig. 5. Forward transit time.

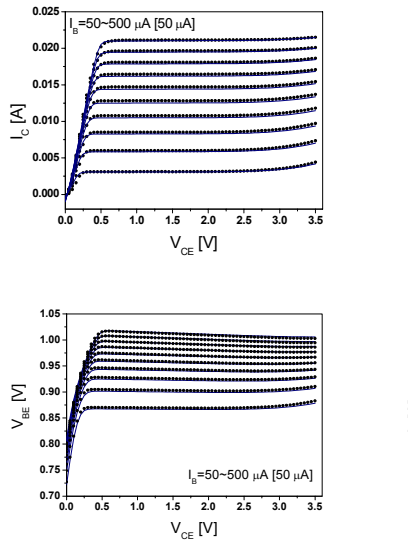

Fig. 7. DC-IV and corresponding  $V_{BE}$  under forward operation at forced  $I_B$ .

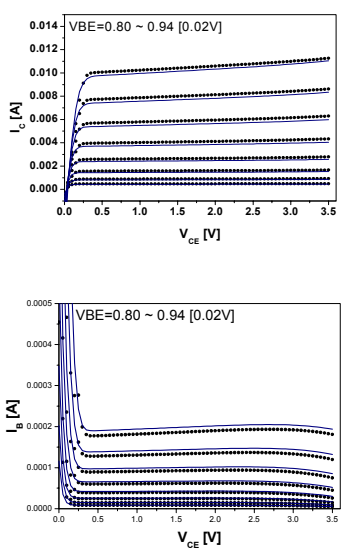

Fig. 8. DC-IV and corresponding  $I_B$  under forward operation at forced  $V_{BE}$ .

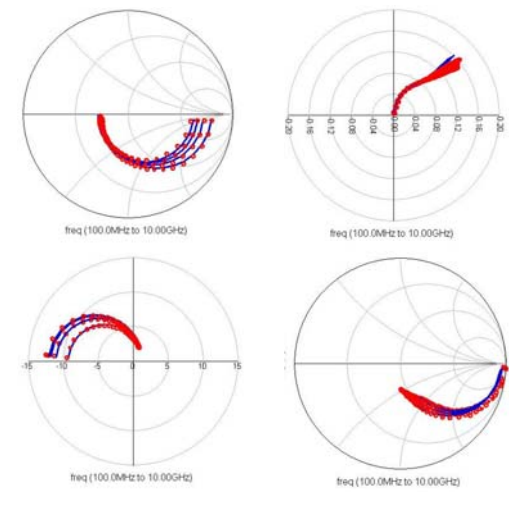

Fig. 9. Measured and simulated S-parameter  $I_c=18\text{mA}$  at  $V_{CE}=1.5\text{V}$ ,  $14.5\text{mA}$  at  $2.0\text{V}$ ,  $10.6\text{mA}$  at  $2.5\text{V}$ , and  $I_c=6.2\text{mA}$  at  $V_{CE}=2.9\text{V}$ .

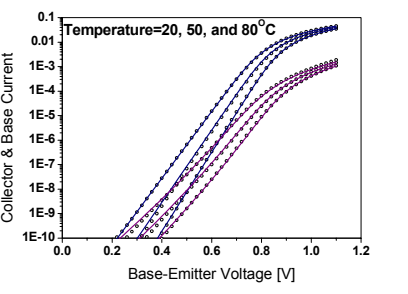

Fig. 6. Measured and simulated Gummel plots for various temperature.

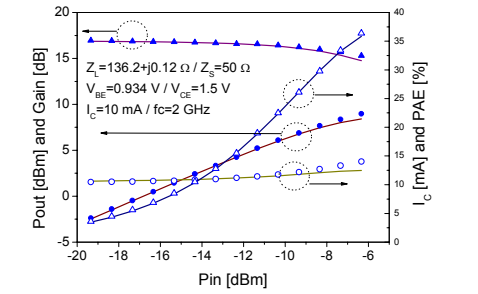

Fig. 10. Measured and simulated RF power characteristics at 2GHz, (a) Pout, Gain,  $I_c$ , and PAE vs. Pin, (b) Pout, IM3, IM5 vs. Pin

