

Design and Analysis of Linear Channel-Selection Filter for Direct Conversion Receiver

Sangsu Jin, Seonghan Ryu, Huijung Kim, Bumman Kim, and Jong-Ryul Lee*

Abstract—An active RC 2nd order Butterworth filter suitable for a baseband channel-selection filter of a direct conversion receiver is presented. The linearity of the 2nd order Butterworth filter is analyzed. In order to improve the linearity of the filter, the operational amplifiers should have a high linear gain and low 3rd harmonic, and the filter should be designed to have large feedback factor. This second order Butterworth filter achieves -14dBV in-channel (400kHz, 500kHz) IIP3, +29dBV out-channel (10MHz, 20.2MHz) IIP3 and $15.6 \text{ nV}/\sqrt{\text{Hz}}$ input-referred noise and dissipates 10.8mW from a 2.7-V supply. The analysis and experimental results are in good agreement

Index Terms—Analog integrated filter, passive matrix frequency tuning, linearity analysis, operational amplifier (OPAMP), active-RC filter, channel-selection filter.

I. INTRODUCTION

The demands of radio integration for low cost solution are very high these days. The direct conversion architecture is obviously favored since it can eliminate intermediate frequency (IF) circuitry like surface acoustic wave (SAW) filters and minimize die area of

the integrated circuits [1]. In WCDMA DCR, after downconversion to zero-IF, the baseband chain performs two major roles, channel selection and gain adjustment for accommodating a 100dB dynamic range input signal. The environment which the chain faces is crucial since strong out-of-band interferers are downconverted together with weak in-band signals by the zero-IF mixer. This places a more challenging set of requirements on the baseband circuits of the integrated receivers. Thus, the chain should have high IIP3 and IIP2 due to the high interferers and low noise figure (NF) due to the weak in-band signal. Figure 1 shows a simplified diagram of the designed baseband stage which adopts partitioning of the chain between gain and filtering for an optimum solution [2]. The sixth order filter is divided into two stages: second order and fourth order filters. Among these circuit blocks of DCR baseband stage, the Butterworth filter is the first block of baseband, so linearity and noise figure characteristics of this pre-filter is important. In this paper, we focus on the linearity of the filter.

The role of a channel-selection filter in DCR is to select the desired signal following RF mixer without any distortion and to reject the out-of-band signal. If harmonic blockers pass through the filter without attenuation, a baseband circuit may be saturated by the large blocker. Then, the intermodulation products generated inside of the baseband chain can degrade the bit error rate (BER). Consequently, the channel-selection filter should have a good linearity and sharp channel-selection [3]. It is a difficult task to satisfy these requirements and is a key point in the design of the integrated channel-selection filter for DCR. In order to achieve the highly linear performance in the integrated filter, active RC filter is employed quite often [4, 5]. This paper shows the design methodology for the linear

Manuscript received June 28, 2004; revised December 7, 2004.
Department of Electrical Engineering, MMIC Lab, POSTECH,
Pohang, Gyungbuk, 790-784, Korea

*Future Communications IC, <<Sunnam>, Kyounggi-Do,
<Korea>>

E-mail: codeone@postech.ac.kr

filter and utilizing the analysis, the filter is designed and implemented. In section II, the analysis of the linearity of filters related to OPAMP properties and passive components used in filters is discussed. In section III, the design of the filter having good linear performance is discussed. Implementation and measurement results are provided in Section IV. Finally, conclusions of this work are made in section V

II. LINEARITY ANALYSIS

For a balanced design, the second harmonic does not exist if there are not any process variations. Thus, the third harmonic is the important criterion of the linearity and analysis of the third harmonic gives us a good way to improve the linearity. Since a filter has memory like capacitor or inductor, we use volterra series for the analysis which is a powerful tool for weakly nonlinear behavior with memory effect. A circuit behaves weakly nonlinear if, for the applied input signal, it can be accurately described by the first terms of its volterra series.[6]

An input of given in equation (1) is applied to a nonlinear circuit, then output of the equation (2) is generated. In the equation (2), coefficients $a_0, a_1, a_2,$ and a_3 represent the dc, linear gain, second harmonic, and third harmonic conversion factors, respectively.

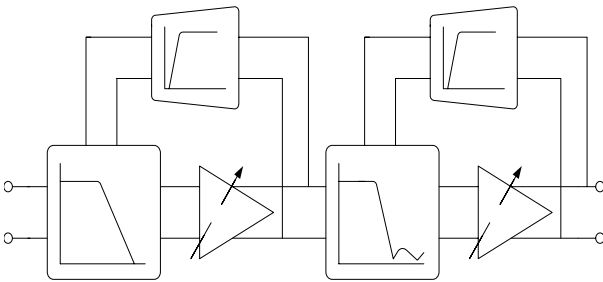

Fig. 1. Diagram of the designed baseband stage

$$x(t) = U \cos(\omega t) \tag{1}$$

$$y(t) = (a_0 + \frac{a_2}{2} U^2) + (a_1 + \frac{3}{4} a_3 U^2) U \cos(\omega t) + \frac{a_2}{2} U^2 \cos(2\omega t) + \frac{a_3}{4} U^3 \cos(3\omega t) + \dots \tag{2}$$

Applying negative feedback to this nonlinear circuit, we can model the equivalent circuit of figure 2 [7].

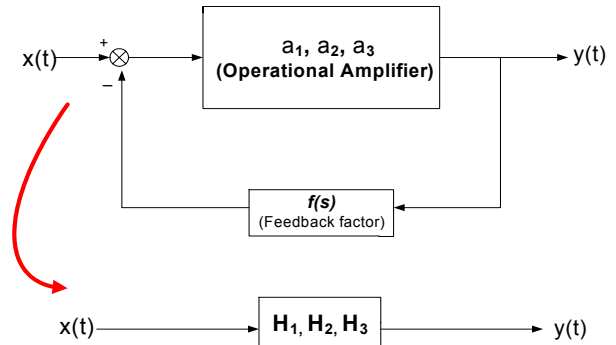

Fig. 2. Equivalent model of a feedback circuit.

$$H_1(s_1) = \frac{a_1}{1 + a_1 f(s_1)} \tag{3a}$$

$$H_2(s_1, s_2) = \frac{1}{1 + f(s_1) a_1} \times \frac{a_2}{1 + f(s_2) a_1} \times \frac{1}{1 + f(s_1 + s_2) a_1} \tag{3b}$$

$$H_3(s_1, s_2, s_3) = \frac{1}{1 + a_1 f(s_1)} \times \frac{a_3}{1 + a_1 f(s_2)} \times \frac{1}{1 + a_1 f(s_3)} \times \frac{1}{1 + a_1 f(s_1 + s_2 + s_3)} \tag{3c}$$

Coefficients $H_1, H_2,$ and H_3 in equation (3) represent Volterra Kernels of equivalent linear, second, and third harmonic gains of feedback circuit using volterra series, respectively. Coefficient f represents the transfer function of unilateral feedback network [8].

A second order active RC filter can be modeled using this approach as shown in figure 3, where the filter is composed of two integrators.

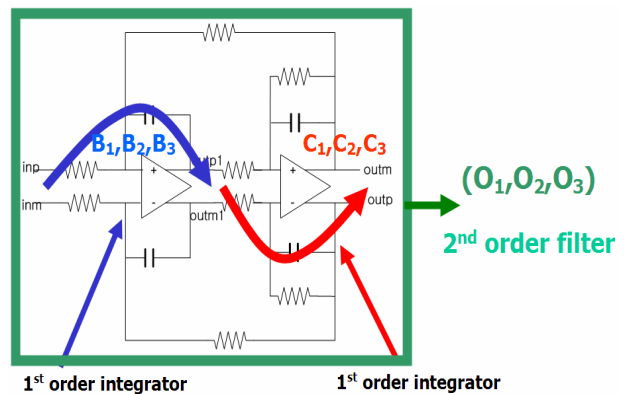

Fig. 3. Modeling of a 2nd order filter.

In order to find the transfer functions of each integrator, feedback factors of each integrator $f_{B1}(s)$ and $f_{C1}(s)$ should be known.

$$f_{B1}(s_1) = sR_1C_1 + \frac{R_1R_3}{R_f(R_2 + s_1R_3R_2C_2)} \quad (4a)$$

$$f_{C1}(s_1) = \frac{R_2}{R_3} + s_1C_2R_2 \quad (4b)$$

Although the first stage feedback loop includes the second stage feedback loop, nonlinear properties of that feedback loop are neglected. Because the feedback loop consists of passive components, the feedback loop does not generate any harmonics. The transfer functions of the linear gain, second, and third harmonics of each integrator can be represented by equation (3). The transfer function properties of each integrator are denoted by B1, B2, B3 and C1, C2, C3. Coefficients O1, O2, and O3 in equation (5) representing the transfer functions of the second order filter are obtained by cascading the two integrators.

$$O_1(s_1) = B_1(s_1) \times C_1(s_1) \quad (5a)$$

$$O_2(s_1, s_2) = C_1(s_1, s_2) \times B_2(s_1, s_2) + C_2(s_1, s_2) \times B_1(s_1) \times B_1(s_2) \quad (5b)$$

$$O_3(s_1, s_2, s_3) = C_3(s_1, s_2, s_3) \times B_1(s_1) \times B_1(s_2) \times B_1(s_3) + C_1(s_1 + s_2 + s_3) \times B_3(s_1, s_2, s_3) \quad (5c)$$

IIP3 of the filter is defined by

$$IIP3i(\text{dBV}) = IMDi * 0.5 + \text{input}(\text{dBV}) \quad (6)$$

where

$$\text{input}(\text{dBV}) = 20 * \log(V_{\text{input}}) \quad (7a)$$

$$IM3(\text{dBV}) = 20 * \log\left(\frac{3}{4} * O_3(s_1, s_1, -s_2) * V_{\text{input}}^3\right) \quad (7b)$$

$$IMDi(\text{dBV}) = \text{input}(\text{dBV}) - (IM3 - \text{Gain}) \quad (7c)$$

Figure 4 shows the comparison between the analysis based on equation (5) using MATLAB and simulation using Agilent Advanced Design System (ADS). The calculated linear gain of the filter denoted by O1 matches very closely to the simulation results. However, the third harmonic denoted by O3 differs from the simulation with increasing frequency. The difference between the simulation and analysis are caused by neglecting the harmonics over fifth order in the calculation, assuming perfect cancellation of even order harmonics in differential mode operation, and neglecting the nonlinear characteristics of the feedback loops.

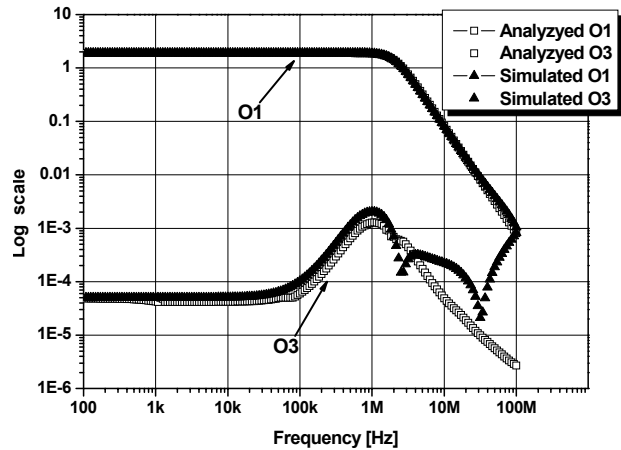

Fig. 4. Comparison of analysis results.

Based on the result of the analysis, we can see that the linearity of the filter can be improved by implementing an OPAMP with a high linear gain and low third harmonic. The high feedback factor at the price of lower gain also enhances the linearity. Also, the large bandwidth of an OPAMP improves a linearity of the filter since lower third intermodulation (IM3) can be achieved at a high frequency. However, methods of transistor scaling and consuming more currents for larger bandwidth of an OPAMP are in trade-off.

III. FILTER DESIGN

Based on the analysis of section II, a second order active- RC Butterworth filter is designed as shown in figure 2. This filter has cut-off frequency of 2.1 MHz with 5dB transfer gain. Its role is a pre-filter in front of the fourth order elliptic filter for WCDMA applications. The equation (8) represents the transfer function of the filter.

$$H(s) = \frac{1}{s^2 + s \frac{1}{C_1R_3} + \frac{1}{C_1C_2R_fR_2}} \quad (8)$$

and $\omega_n^2 = \frac{1}{C_1C_2R_fR_2}$, DC-Gain = $\frac{R_f}{R_1}$

The transfer gain, cut-off frequency, and noise performance are defined by both resistors and capacitors. Because noise performance is determined by passive

resistors, it is necessary to select appropriate values of resistors [9, 10,11]. In section 2, we find that OPAMP are the most important in active-RC filter design. The schematic of the OPAMP used in the filter is shown in figure 5. It is implemented by differential mode and the common mode voltage at the output load is defined by common mode feedback circuit (CMFB) [12]. In order to improve DC-gain we employ two stages for OPAMP, BJT input core, cascoded active load stage and choose a large gate length CMOS for active load. Since OPAMP noise is a part of filter noise we employ PMOS active load for the first stage of amplifier and chose a large gate length PMOS to reduce 1/f noise. Current consumption of each OPAMP is 0.75mA and common mode voltage is 1.5V.

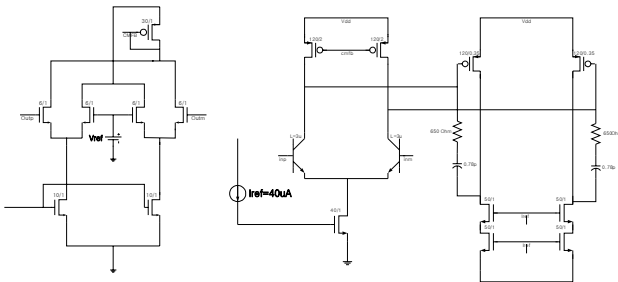

Fig. 5. Fully differential OPAMP circuit with CMFB.

The cut-off frequency of an active RC type filter is defined by passive component values. Due to the variations in Bi-CMOS process the actual resistance and capacitance values of the integrated components may differ from the nominal values. These variations mean the variation of the cut-off frequency in the filter. Tuning circuit to compensate these variations has to be made tunable in active RC filter. A capacitor and resistor matrices shown in figure 6, make each value controllable with possible tuning range of $\pm 20\%$ of the reference values

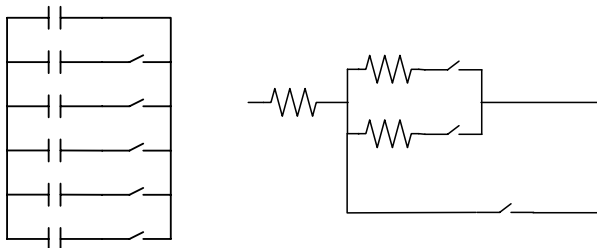

Fig. 6. Passive matrices.

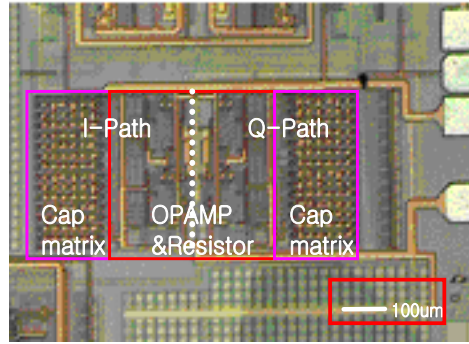

Fig. 7. Microphotograph of the chip.

Figure 7 shows the chip photo using STM 0.35um Bi-CMOS technology. The chip consists of two filters for I-Q path and the size is 520um*310um. The capacitor and resistor matrices occupy 70% of the chip area

IV. MEASUREMENT RESULTS

For measurement, a passive transformer is used to convert the input and output signals from single ends to differential modes, and vice versa. The supply voltage is 2.7V. Figure 8 shows the measured tunable frequency response of the filter. The filter satisfies the cut-off frequency of 2.1MHz for WCDMA systems with the tunable frequency range of about 1.5MHz ~ 3.7MHz with total gain of 5dB. The linearity of the filter is measured for both in-channel and out-channel IIP3. To measure the in-channel linearity, two tones of 300kHz and 500kHz, and out-channel linearity, 10MHz and 20.2MHz, are used. Figure 9-10 shows the measured and simulated IIP3 results of the filter according to input power variations. The measured performance is summarized in Table I.

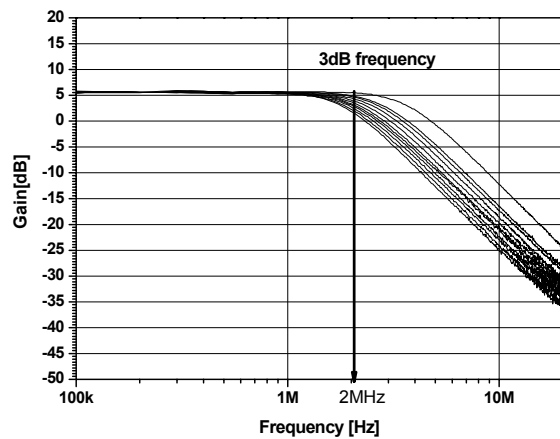

Fig. 8. Passband response of the filter.

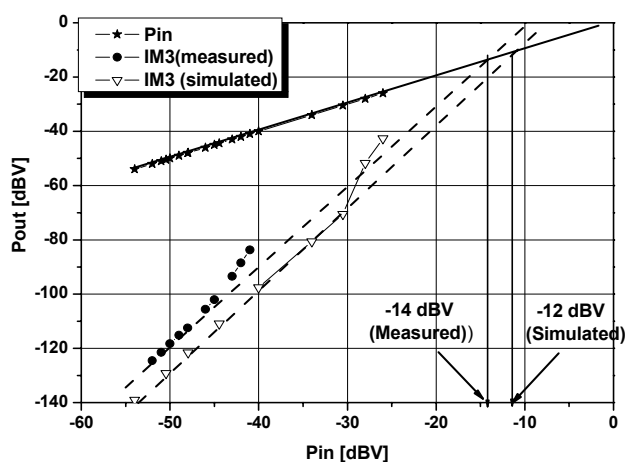

Fig. 9. In-channel IIP3

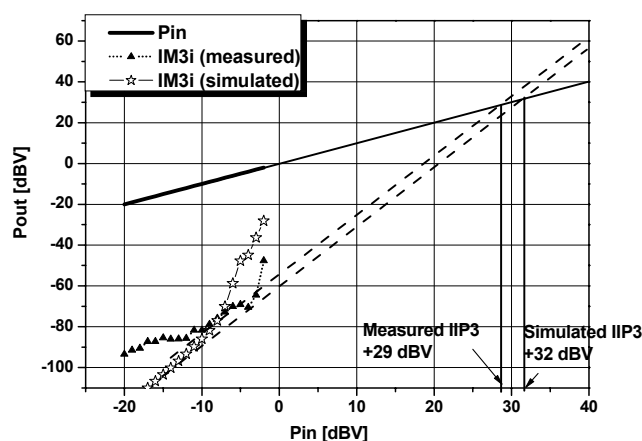

Fig. 10. Out-channel IIP3.

Table 1. Summary of the filter performance.

Supply voltage	2.7V
Current consumption 2 nd -Butterworth filter	4 mA (I-Q included)
Cut-off frequency	2.1 MHz
In-band gain	5 dB
In-channel IIP3	-14 dBV
Out-channel IIP3	29 dBV
Input-referred noise	15.6 nV/ $\sqrt{\text{Hz}}$
Out-of-band rejection (@ 10MHz)	26 dB

V. CONCLUSION

A second-order active RC channel-selection filter for DCR is presented. The filter meets the bandwidth specification of WCDMA standard using RC components tuning. The important linearity performance

of the filter is analyzed and measured. In this paper, it is confirmed that the linearity of the active RC filter is dependent on the performance of the OPAMP. Based on these results, it shows that, to improve the linearity of the filter, the transfer gain of the filter should be made lower, linear gain properties of the OPAMP higher, 3rd-harmonics of the OPAMP smaller, and the OPAMP bandwidth wider.

ACKNOWLEDGEMENT

The authors are grateful for the support of IDEC and BK21 program.

REFERENCES

- [1] Hollman, T., Lindfors, S., Lansirinne, M., Jussila, J., and Halonen, K.A.I., "A 2.7-V CMOS dual-mode baseband filter for PDC and WCDMA," *IEEE Journal of Solid-State Circuits*, vol. 36, pp. 1148 - 1153, July 2001.
- [2] Waite, H., Ta, P., Chen, J., Li, H., Gao, M., Chang, C.S., Chang, Y.S., Redman-White, W., Charlton, O., Fan, Y., Perkins, R., Brunel, D., Soudee, E., Lecacheur, N., Clamagirand, S., "A CDMA2000 Zero-IF Receiver with Low-Leakage Integrated Front-End," *IEEE Journal of Solid-State Circuits*, vol. 39, pp. 1175 - 1179, July 2004.
- [3] Groenewold, G., "Optimal dynamic range integrators," *Circuits and Systems I: Fundamental Theory and Applications, IEEE Transactions on*, vol. 39, pp. 614 - 627, Aug. 1992.
- [4] Yoshizawa, A. and Tsividis, Y.P., "Anti-blocker design techniques for MOSFET-C filters for direct conversion receivers," *Solid-State Circuits, IEEE Journal of*, vol. 37, pp. 357 - 364, Mar. 2002.
- [5] L.O.Chua and P.M.Lin, *computer-aided analysis of electronic circuits: algorithms & computational techniques*, Prentice-Hall, 1975.
- [6] Tsividis, Y.P., "Continuous-time filters in telecommunication chips," *communications Magazine, IEEE*, vol. 39, pp. 132 - 137, Apr. 2001.

- [7] Willy Sansen, "Distortion in Elementary Transistor Circuits," *IEEE Trans. on Circuits and Systems II: Analog and Digital Signal Processing*, vol. 46, pp. 315-325, Mar. 1999.
- [8] Piet Wambacq and Willy, Sansen, *Distortion Analysis of Analog Integrated Circuit*. The Netherlands: Kluwer Academic Publishers, 2001.
- [9] H. Bachler and W. Guggenbuhl, "Noise analysis and comparison of second-order networks containing a single amplifier," *IEEE Trans. on Circuits and Systems*, vol. 27, pp. 85-91, Feb. 1980.
- [10] P. Bowron and K. A. Mezher, "Noise analysis of second-order analogue active filter," *IEE Proc. Circuits, Devices and Systems*, vol. 141, pp. 350-356, Oct. 1994.
- [11] 이승현, 진상수, 김희중, 김범만, "Noise and linearity analysis and minimizing strategy of Elliptic filter." 2003 SoC Design Conference, pp. 473-477, Nov. 2003.
- [12] Lah, L., Choma, J., and Jr. Draper, J., "A continuous-time common-mode feedback circuit (CMFB) for high-impedance current-mode applications," *Circuits and Systems II: Analog and Digital Signal Processing, IEEE Transactions on*, vol. 47, pp. 363 - 369, Apr. 2000.



Sangsu Jin received the B.S. degree from the Department of Electronic Engineering and Computer Science from Hanyang University, Ansan, Korea, in 2003. He is currently pursuing the M.S degree in the Department of Electronic Engineering

at Pohang University of Science and Technology. His interests include CMOS RF circuits and high-frequency analog circuit design for wireless communications



Sunghan Ryu received the B.S. degree from the Department of Electronic Engineering from Kyungbook National University, Daegu, Korea, in 1998, the M.S. degree from the Pohang University of Science and Technology,

Pohang, Korea, in 2000. He is currently pursuing the Ph.D. degree in the Department of Electronic Engineering at Pohang University of Science and Technology. His interests include CMOS RF circuits and high-frequency analog circuit design for wireless communications



Huijung Kim received the B.S and M.S degrees in the Department of Electronic Engineering from Pohang University of Science and Technology, Pohang, Korea, in 2000 and 2002, respectively. He is currently pursuing the Ph.D. degree

in the Department of Electronic Engineering at Pohang University of Science and Technology. His interests include CMOS RF circuits for wireless communications, high-frequency analog circuit design and mixed-mode signal processing IC design



Jong-Ryul Lee received the B.S. and M.S. degrees in electronic engineering from Chung-Ang University, Seoul, Korea in 1988 and 1990 respectively. From 1990 to 2000, he participated in the development of Analog Mixed Circuit Design for wireless

communication at ETRI(Electronics Telecommunication Research Institute) in Taeduk Science Town. Since 2000, he has been with Future Communications IC Inc. in Pundang, Korea, as Director of the CDMA wireless solution Transceiver Chips and subsequently Vice President of Production Department.



Bumman Kim received the Ph.D. degree in electrical engineering from Carnegie-Mellon University, Pittsburgh, PA, in 1979. From 1978 to 1981, he was engaged in ber-optic network component research with GTE Laboratories Inc. In 1981, he joined the Central Research Laboratories, Texas Instruments Incorporated,

where he was involved in development of GaAs power FETs and MMICs. He has developed a large-signal model of a power FET, dual-gate FETs for gain control, high-power distributed amplifiers, and various millimeter wave MMICs. In 1989, he joined the Pohang University of Science and Technology (POSTECH), Pohang, Korea, where he is Namko Chaired Professor in the Electronic and Electrical Engineering Department, and Director of the Microwave Application Research Center. Currently, he is involved in device and circuit technology for RFIC, especially the linear power amplifiers. In 2001, he was Visiting-Professor at the department of Electrical Engineering, California Institute of Technology (Caltech), Pasadena California. He has authored over 150 published technical papers. Dr. Kim is a member of the Korean Academy of Science and Technology and Academy of Engineering of Korea. He is an associate editor for the IEEE TRANSACTIONS ON MICROWAVE THEORY AND TECHNIQUES.